

MOTORIZED DIAMOND WHEEL DRESSER

**Machine Model 162**



 [Operating and Parts Manual](#)

**Price: US\$ 2,041.00**

**Radius attachment US\$ 455.00**

Shown with optional radius grinding attachment

Price and specification subject to change without notice

**Applications**

**Features**

- ▣ Slide feature allows dressing of angles on periphery and face wheels
- ▣ Attaches quickly to the work table eliminating the need for special wheel truing jigs
- ▣ Restores original configuration, repeatedly, effortlessly, precisely
- ▣ Dresses your diamond wheel right on the spindle for the ultimate consistent precision
- ▣ All your wheels will cut at top efficiency for maximum production and run consistently true for the finest finishes
- ▣ Rugged construction assures true running and long life
- ▣ Silicon Carbide and Aluminum Oxide grinding wheels available from stock

- ▣ Built-in Vernier Scale for Precise Angular Adjustment of: 5° through 360°
- ▣ 4" Dressing Wheel Travel on Ground Dovetail Ways
- ▣ Dressing Wheel Size: 1/2" x 1/2" x 4"
- ▣ Overall length: 10"
- ▣ Over Height: 6"
- ▣ Shipping Weight: 32 lbs.
- ▣ Metal Storage Case
- ▣ Double and single row shaft bearings maintain precise alignment for smooth and accurate dressing
- ▣ The machine is designed to function properly in the presence of abrasive dust to provide years of trouble free, and accurate service
- ▣ Available with 110/220v 50/60 cycles

**Optional Radius Attachment**

- ▣ Swing of Radius Attachment: 180°
- ▣ Micrometer Incremental Advance of Dresser: .001"

MOTORIZED DIAMOND WHEEL DRESSER

**Typical Applications Model 162**

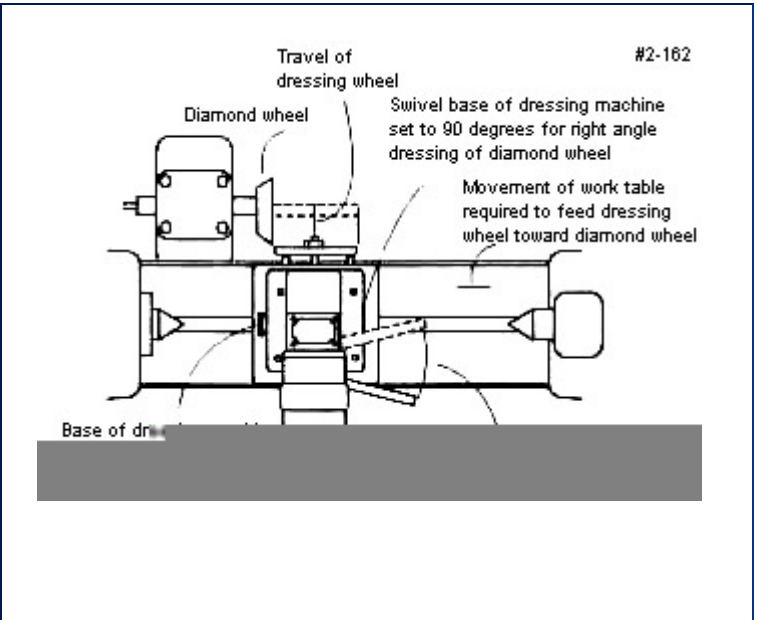
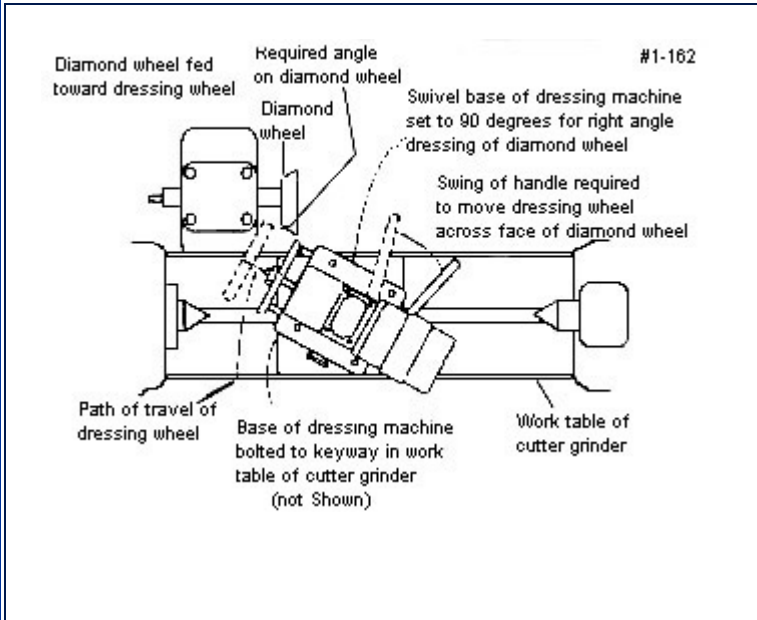

Quick, Repeatable, Accurate Dressing machine secured to machine table-desired angle set with built in vernier scale-swing handle forward advancing dressing wheel into diamond wheel- precise angle restored.

Repeat for useful life of diamond wheel.

Dressing machine bolted to machine table- 90 degree angle established with built in vernier scale- swing handle forward - dressing wheel advanced along face of diamond wheel-true running 90 degree face restored perfectly.

Repeatable.

MOTORIZED DIAMOND WHEEL DRESSER

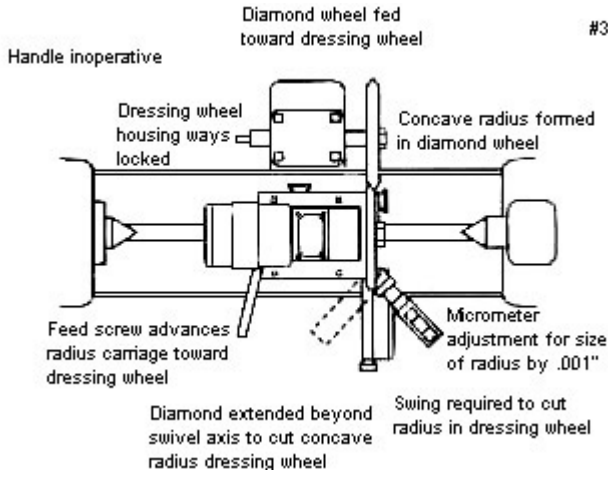
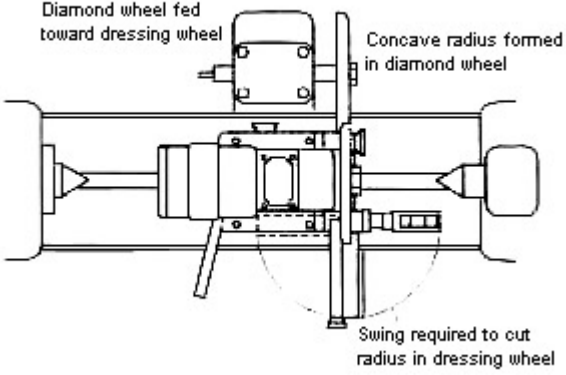
 <p>#3-162</p>	 <p>#4-162</p>
<p>Dressing machine locked of own ways- advance handle inoperative- radius attachment with micrometer radius-size adjustment swing through concave radius-convex radius trued on diamond wheel.</p> <p>Repeatable.</p>	<p>Dressing machine locked as above- radius attachment swung through full 180 degrees over dressing wheels to true micrometer sized convex radius on dressing wheel- concave radius trued on diamond wheel.</p> <p>All routines repeatable though useful life on diamond wheel.</p>