

TDR/SRD Drill Grinders

Model 80-M



Instructions & Engineering Data



Sharpen drills in 60 seconds



Adjusts automatically between drill sizes



Radial relief on all tools



Simple to learn ~ simple to operate

Manufactured by:

Service Precision Grinding Co., Inc.

Distributed by

Novatech, Inc.

15895 N 77th Street

Scottsdale AZ 85260

Phone 480.991.9445 / Fax 480.991.9465

<http://www.NovatechOnline.com>

Model 80-M TDR/SRD DRILL GRINDER

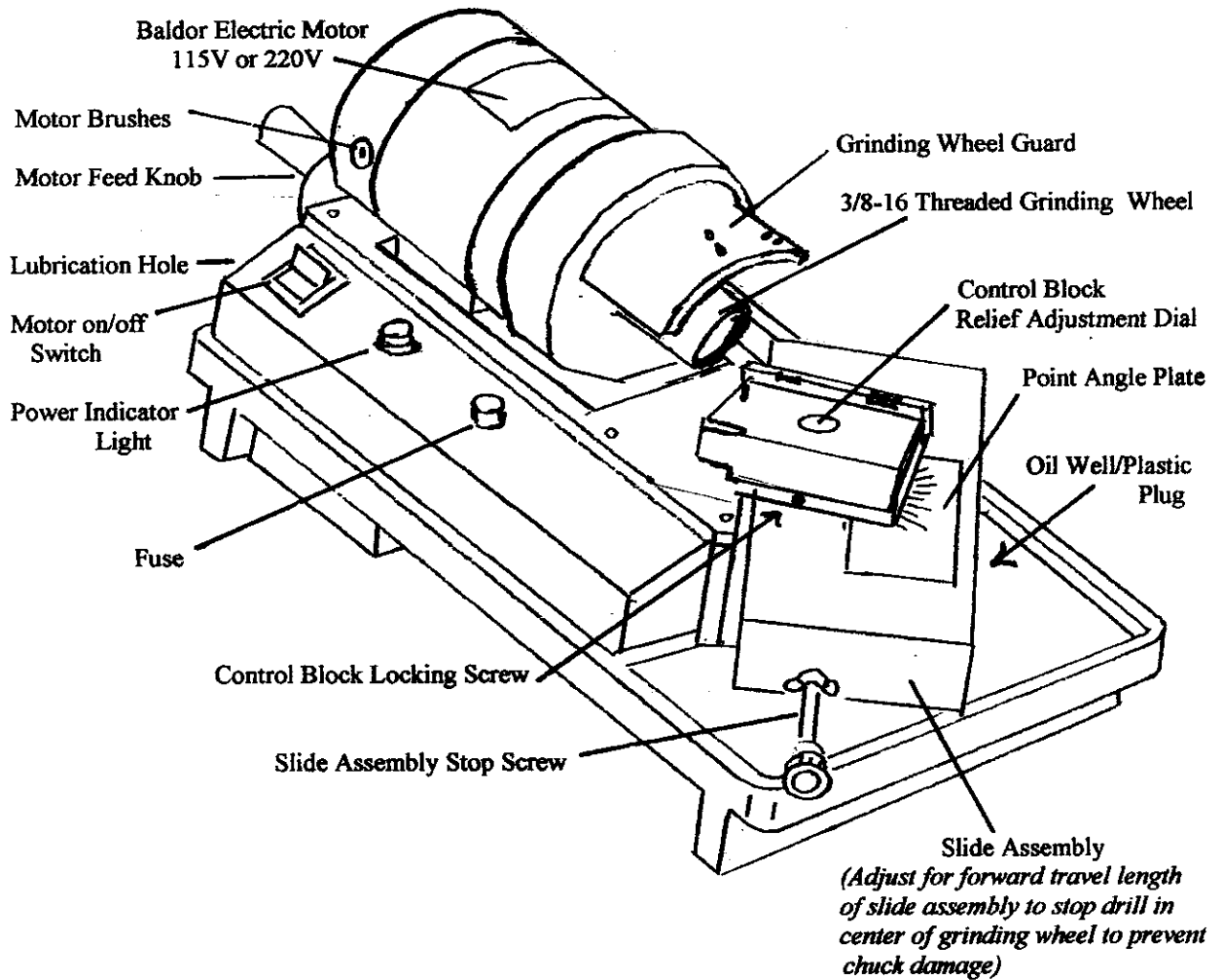

(FIG #1)

Dimensions 10"Wx16"Lx8"H ~ Weight 50 Lbs. ~ Cast iron & steel construction ~ All models built to satisfy industrial quality ~ Totally enclosed Baldor motor ~ Hardened & ground slide rails ~ All movable parts are kept free of grinding dust ~ Serialized and inspected drill chucks ~ Drill point concentricity .001" lip to lip ~ Hardcoated aluminum fixtures for extended life ~ Increased versatility with additional fixtures ~ Precise results every time ~ Angle range 85 degree to 160 degrees ~ Relief angles 0 degrees to 20 degrees ~ Made in the USA

Customize point angles and clearances to achieve the most efficient feed rates for your job!

Grinding wheels and additional fixtures are listed on page 6

NEED TO KNOW & SETUP

WARRANTY:

All machines manufactured by Service Precision Grinding Co., Inc. carry a one year warranty against defective parts or workmanship. Technical and service information is available directly from the manufacturer.

CAUTION:

Safety glasses must be worn when using this grinding machine. Safety Regulations normally required must be adhered to when using this machine as any other machine you operate.

WARNING:

To avoid the affects of dust from grinding please follow normally required procedures for health and safety. Grinding generates dust which can affect breathing functions.

MACHINE MAINTENANCE:

The top slide oil has been drained for shipment. Remove the plastic oil reservoir plug (Fig #2) Replace oil with standard S.A.E. 30 weight oil. (*correct level is bottom of refill hole*).

Weeping oil from the slide assembly rails (Fig #2) is normal and serves to keep slide rails free of grinding dust. It is not necessary to maintain the oil level at all times. The slide assembly will be lubricated as long as there is some oil in the reservoir.

Occasional lubrication of the motor lead screw can be done by dropping oil thru the 1/4" hole in the sheet metal (Fig #1) near the motor feed knob. The motor feed knob can be lubricated directly by dripping oil between the knob and the base casting then rotating the knob several times.

Disconnect the power supply before inspecting motor brushes (Fig #1) for possible replacement. Motor brushes should be replaced when length is less than 1/4" long.

GRINDING WHEELS:

With the machine power off, locate a screw drive in the slot at the end of the motor shaft found inside the grinding wheel (Fig #3). Hold the wheel with your free hand and unscrew it from the shaft. This is a right threaded motor shaft. Screw on the replacement wheel till it butts up against the wheel flange (Fig #3). Vitrified wheels require that a paper blotter be in place between the wheel and the flange. Paper blotters are not used for diamond wheels. During normal grinding operations there is no need to dress the grinding wheels. Use only abrasive wheels designed and made for TDR/SRD Drill Grinders.

(FIG # 2)

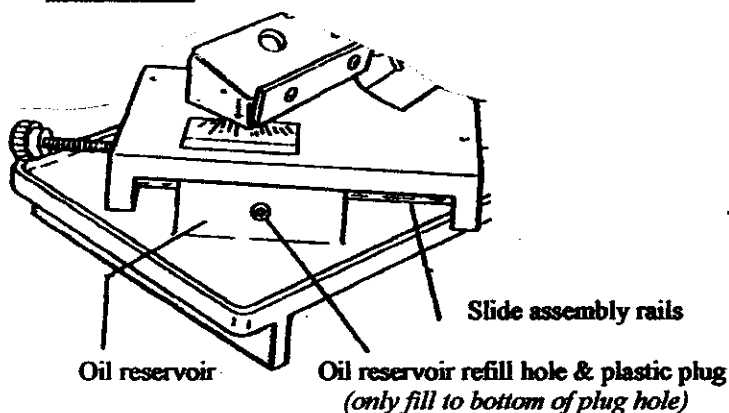

(FIG # 3)

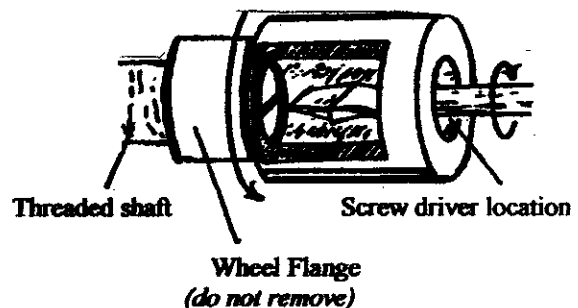

CONTROL BLOCK SETTINGS

The 1/8" hex key is used to unlock the control block locking screw located in the front of the control block (Fig #4). The control block raises, lowers and rotates. Different settings change the relationship of the drill cutting edge to the grinding wheel. When the control block is unlocked point angles can be changed by aligning the vertical scribe line, on the side of the chuck, with the desired point angle on the point angle plate. The calibrations on the relief adjustment dial allows for precise adjustments to the drill cutting edge clearance. The small relief screw roll pin is lined up with the appropriate calibration on the dial by inserting the 1/8" hex key down into the relief screw socket (Fig #4), holding the control block, and turning the hex key. The drill grinder is shipped at the standard settings of 118 degree point angle with 10 degrees clearance (Fig # 5). These are the settings for a standard twist drill. There is no need to adjust settings every time you change drill sizes. To reduce the clearance of the drill turn the relief screw in a clockwise direction to raise the block. Turn the screw in a counter clockwise direction to lower the block and increase the clearance. The control block locking screw also locks the relief dial.

(FIG #4)

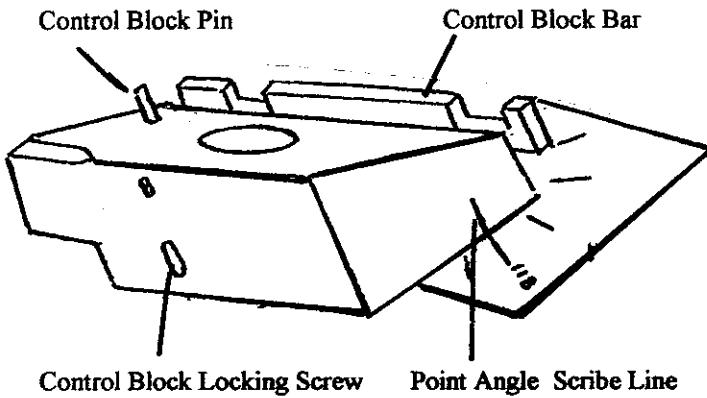

(FIG #5)

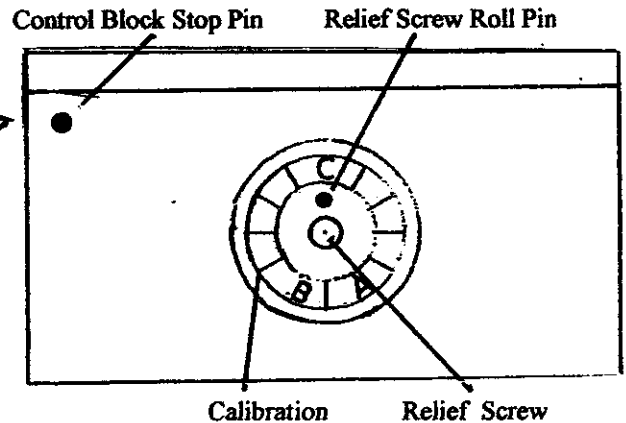

Common Drill Point Angles & Clearance Settings

| <u>Drill Types</u> | <u>Control Block Settings</u> | <u>Lip Relief Settings</u> |
|----------------------|-------------------------------|----------------------------|
| Standard Twist Drill | point angle at 118 | C |
| Cobalt Drills | point angle at 135 | A |
| Center Drills | point angle at 118 | C |

It is generally agreed that less clearance on the tool the more accurate and rounder the hole. It will require more torque to cut but the tool will last longer. Make a note of favorite settings for repeat grinding geometry.

LOADING & GRINDING DRILLS

1/16" to 13/16"~(1.5mm-20.5mm)

The fixtures and proper diameter wheel, needed for sharpening drills in the 1/16"-13/16" range, are listed on page 3.

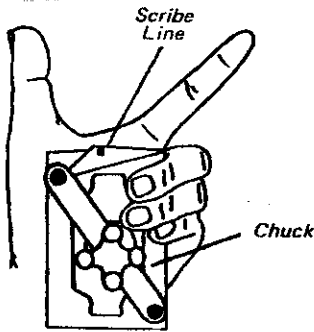

Step -1-

The scribed lines on the face of the chuck are used to align the drill for sharpening. The alignment is done by eye. If the alignment is off it is not a concern as it affects the heel angle only. To load the drill hold the chuck in an upright position.

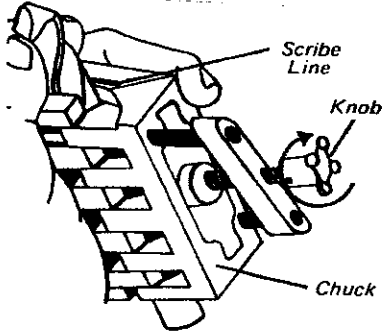

Step -2-

The chuck is opened by turning the chuck knob counter clockwise then inserting the drill into the chuck face shank first.

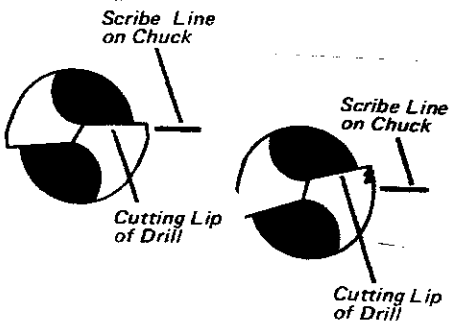

Step -3-

Turn the drill in the chuck to align the cutting edges slightly above the scribed lines on the face of the chuck. For badly worn or broken drills it may be necessary to have the cutting edge set beyond the scribe line.

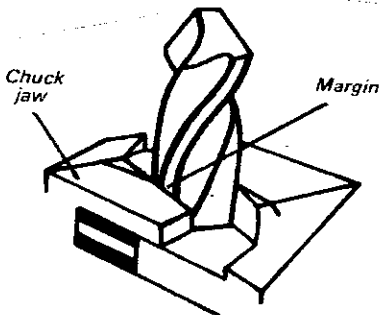

Step -4-

Move the drill in or out of the chuck till the first margin of the drill is firmly engaged with the chuck. Clamping on the margin of the drill assures concentricity and absolute stability of the drill. Drills 1/4" and larger are clamped on the first margin, smaller drills are clamped on the second margin. Using the chuck knob lock the drill in place with a light touch.

LOADING & GRINDING DRILLS 1/16" to 13/16"~(1.5mm-20.5mm)

Step -5-

Position the side of the chuck on the control block with the knob facing the operator. While holding the chuck against the pin and back bar move the slide assembly forward and turn the motor knob to bring the wheel forward. Until the drill is just clearing the inside edge of the grinding wheel.

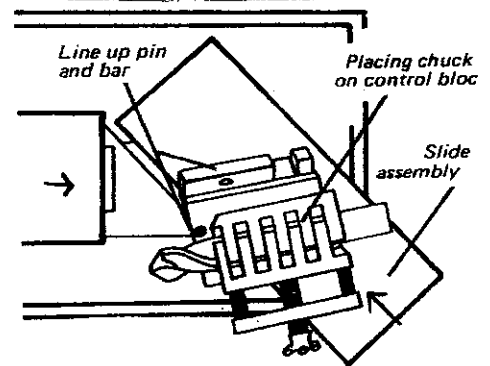

Step -6-

Adjust the slide assembly stop screw so that the drill passes all the way across the the face of the wheel at 8-9 o'clock. Setting the stop screw prevents the chuck from hitting the wheel during the forward stroke

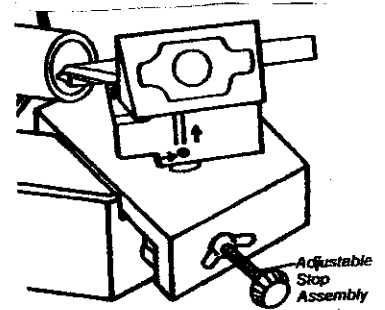

Step -7-

Put on safety glasses! Turn the motor on and while holding the drill chuck firmly against the pin and bar move the slide assembly back and forth passing the drill in and out of the wheel. Turn the motor feed knob until the drill and the wheel engage and sparks appear.

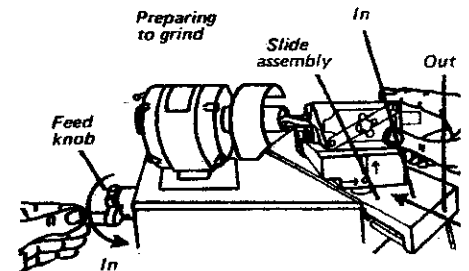

Step -8-

Using the suggested hand positions continue moving the drill across the wheel using a series of short and quick passes until the sparks appear faint.

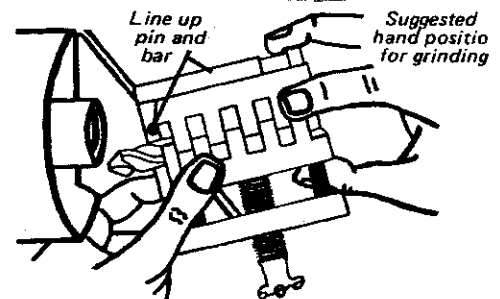

Step -9-

Do not advance the feed knob and do not remove the drill from the chuck. Simply flip the chuck 180 degrees and sharpen the second lip as you did the first.

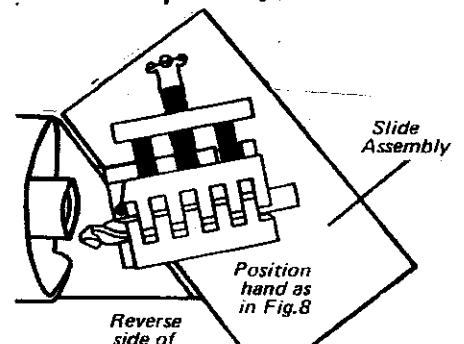

THINNING THE WEB FOR SELF CENTERING

After a drill has been sharpened it may be beneficial to thin the web of the drill. Thinning the web strengthens the point of the drill and, at the same time, a center is formed that supports the body of the drill before the point begins to cut. Webs become thicker as drills become shorter and thinning the web can prolong drill life. Also, web thinning produces a self centering point which helps when drilling into hard material. There are no special attachments used for web thinning simply a readjustment of settings and realignment of the drill in the chuck.

Step - 1-

Grind a drill in the normal manner choosing which ever point angle and clearances are best suited for the job. It is important to have a sharp chisel edge before web thinning.

Step -2-

Realign the cutting edge of the drill 90 degrees to the scribed line, on the face of the chuck, as seen in (Fig #1).

NOTE: To obtain maximum production efficiency, grind all drills first and then set up to web thin in batches.

Step -3-

Set the control block to 85 degrees and the relief dial at C. (Fig #2). Turn the motor feed knob to pull the motor back from the control block. It may be necessary to reset the stop screw to allow the slide full travel. Set the drill chuck on the control block as if the drill were being sharpened and pass on the back of the wheel. After the tip of the heel has been removed flip the chuck and repeat. Continue passing both sides of the drill across the wheel until the drill sparks out in the normal manner and if necessary feed the motor inwards and repeat. Checking the drill point being careful not to bisect the point.

NOTE: As with all instructions, they set the standard procedures and you may determine for yourself the best drill geometry for the job. TDR/SRD Drill Grinders offer you the opportunity to customize point angles and clearances to achieve the most efficient feed rate for your job.

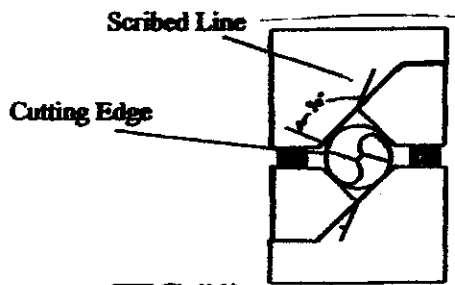

(FIG #1)

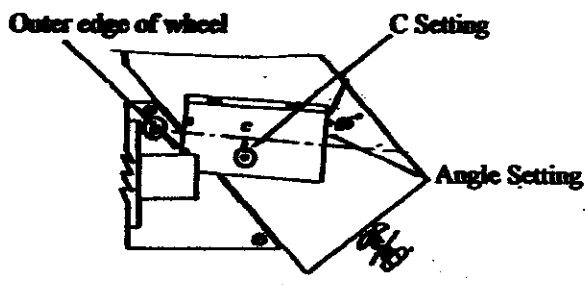

(FIG #2)

Model 80-M TDR/SRD Drill Grinder

GRINDING WHEELS WITH 3/8-16THD ~ 80-M ACCESSORIES

76-M-1790-P 1-3/8"OD ~ Std 90 grit wheel for HSS & Cobalt

76-M-1760-P 1-3/8"OD ~ Fast cut 60 grit wheel for HSS & Cobalt

76-M-1750-P 1-3/8"OD ~ 120 grit silicon/carbide wheel for Carbide

76-M-1770-P 1-3/8"OD ~ Diamond wheel for carbide

80-M-7370-P 3/4"OD ~ 120 grit wheel for HSS & Cobalt
(to be used with riser plate)

~

LHOP/M Left-Hand Drill Option ~ L.H. Drills 1/16"-1/2"

80-S-7340-P Riser Plate ~ Enhances small drill relief ~ use with 80-M-7370-P

76-M-1580-P ~ Standard replacement drill chuck

76-M-1582-P ~ Taper shank drill chuck ~ 1/16" - 13/16"